

Datasheet

Subject to technical alteration
Issue date: 18.05.2018 • A003



Application

Duct averaging temperature sensor in enclosure USE-M for measuring the average temperature in air ducts. The sensor detects the applied temperature value throughout the entire length. With the option board relay two-point controllers or a 2-stage 2-point controller for temperature can be realized. Mounting angles for uncomplicated duct mounting are included in delivery. A spring at the connection head reduces vibrations.

Types Available

Duct/Immersion sensor temperature – active 0..10 V + relay

MWF+ TRV MultiRange Relay L<x> incl. Installation kit

<x>: sensor rod length 3000/6000 mm

Security Advice – Caution



The installation and assembly of electrical equipment should only be performed by authorized personnel.

The product should only be used for the intended application. Unauthorised modifications are prohibited! The product must not be used in relation with any equipment that in case of a failure may threaten, directly or indirectly, human health or life or result in danger to human beings, animals or assets. Ensure all power is disconnected before installing. Do not connect to live/operating equipment.

Please comply with

- Local laws, health & safety regulations, technical standards and regulations
- Condition of the device at the time of installation, to ensure safe installation
- This data sheet and installation manual

Notes on Disposal



As a component of a large-scale fixed installation, Thermokon products are intended to be used permanently as part of a building or a structure at a pre-defined and dedicated location, hence the Waste Electrical and Electronic Act (WEEE) is not applicable. However, most of the products may contain valuable materials that should be recycled and not disposed of as domestic waste. Please note the relevant regulations for local disposal.

Build-up of Self-Heating by Electrical Dissipative Power

Temperature sensors with electronic components always have a dissipative power, which affects the temperature measurement of the ambient air. The dissipation in active temperature sensors shows a linear increase with rising operating voltage. This dissipative power has to be considered when measuring temperature. In case of a fixed operating voltage ($\pm 0,2$ V) this is normally done by adding or reducing a constant offset value. As Thermokon transducers work with a variable operating voltage, only one operating voltage can be taken into consideration, for reasons of production engineering. Transducers 0..10 V / 4..20 mA have a standard setting at an operating voltage of 24 V =. That means, that at this voltage, the expected measuring error of the output signal will be the least. For other operating voltages, the offset error will be increased by a changing power loss of the sensor electronics. If a re-calibration should become necessary later directly on the sensor, this can be done by means of the USEapp software and an optional Bluetooth interface.

Remark: Occurring draft leads to a better carrying-off of dissipative power at the sensor. Thus temporally limited fluctuations might occur upon temperature measurement.

Technical Data

Measuring values	temperature		
Output voltage	0..10 V or 0..5 V, min load 10k Ω (live-zero configuration via Thermokon USEapp)		
Output switch contact	2 floating contacts for 24 V ~ or 24 V = / 3 A		
Power supply	15..35 V = or 19..29 V ~		
Power consumption	max. 2,5 W (24 V =) max. 4,3 VA (24 V ~)		
Output signal range temp. *Scaling analogue output	-20..+80 °C (default setting), selectable from 8 temperature ranges -50..+50 -20..+80 -15..+35 -10..+120 0..+50 0..+100 0..+160 0..+250 °C, optionally configurable via Thermokon USEapp		
Operating temperature range * Max. permissible operating temperature	sensor pocket -50..+80 °C	electronic enclosure -35..+70 °C	mounting base -35..+90 °C
Accuracy temperature	$\pm 0,5$ K (typ. at 21 °C)		
Enclosure	enclosure USE-M, PC, pure white, with removable cable entry		
Protection	IP65 according to EN 60529		
Cable entry	M25 with fourfold cable entry for wire with max. $\varnothing=7$ mm, removable		
Connection electrical	removable plug-in terminal, max. 2,5 mm ²		
Sensor rod	3000 mm, 6000 mm		
Ambient condition	max. 85% rH short term condensation		

Configuration



The Thermokon bluetooth dongle with micro-USB is required for communication between USEapp and USE-M / USE L (Item No.: 668262). Commercial bluetooth dongles are not compatible.



Application-specific reconfiguration of the devices can be carried out using the Thermokon USEapp. The configuration is carried out in the voltage-supplied state.



The configuration-app and the app description can be found in the Google Play Store or in the Apple App Store.

Application notice



The housing cover must be completely closed in order to ensure the accuracy and reproducibility of the measured values during a test or service log via USEapp.

The Bluetooth dongle snaps into the socket easily. When removing, please fix the plug-in card (option PCB) so that it is not unintentionally pulled out.

Mounting Advices

Model MWF can either be mounted directly on the ventilation duct by means of a mounting flange or by screws.

By means of the mounting brackets included the sensor rod is braced to the ventilation duct.

Note: Please pay attention to the sensor rod while mounting and protect it from mechanical damage!

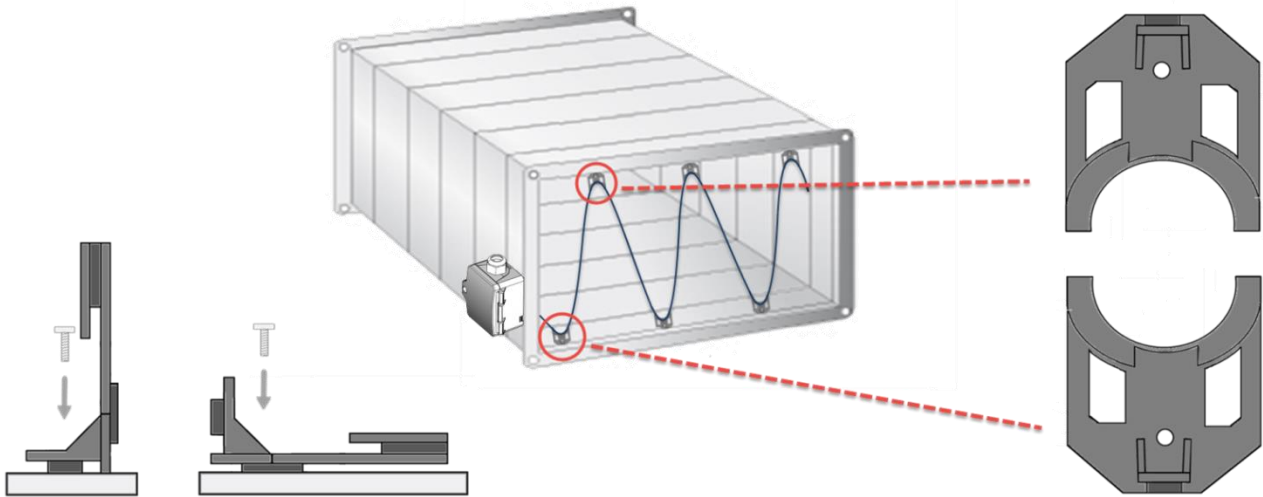

Vertical mounting

Horizontal mounting

Connection Plan

To change the output voltage range (default 0..10 V to 0..5 V) via jumper, the display must be removed from the board first.

MWF+ TRV MultiRange Relay

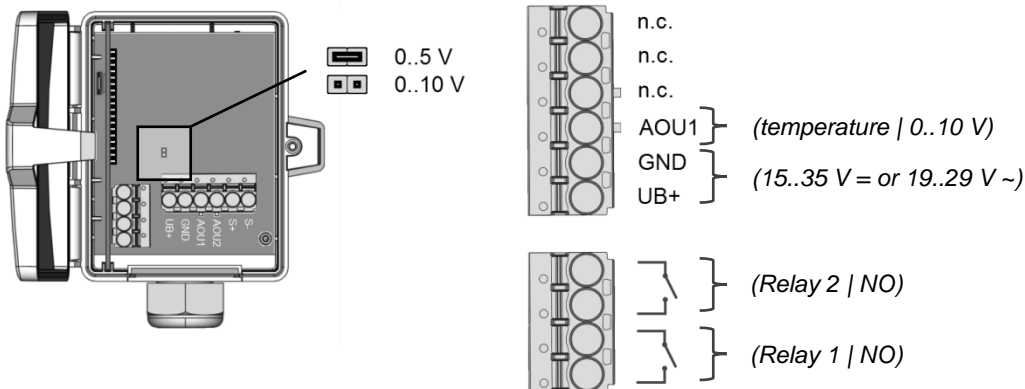

Dimensions (mm)

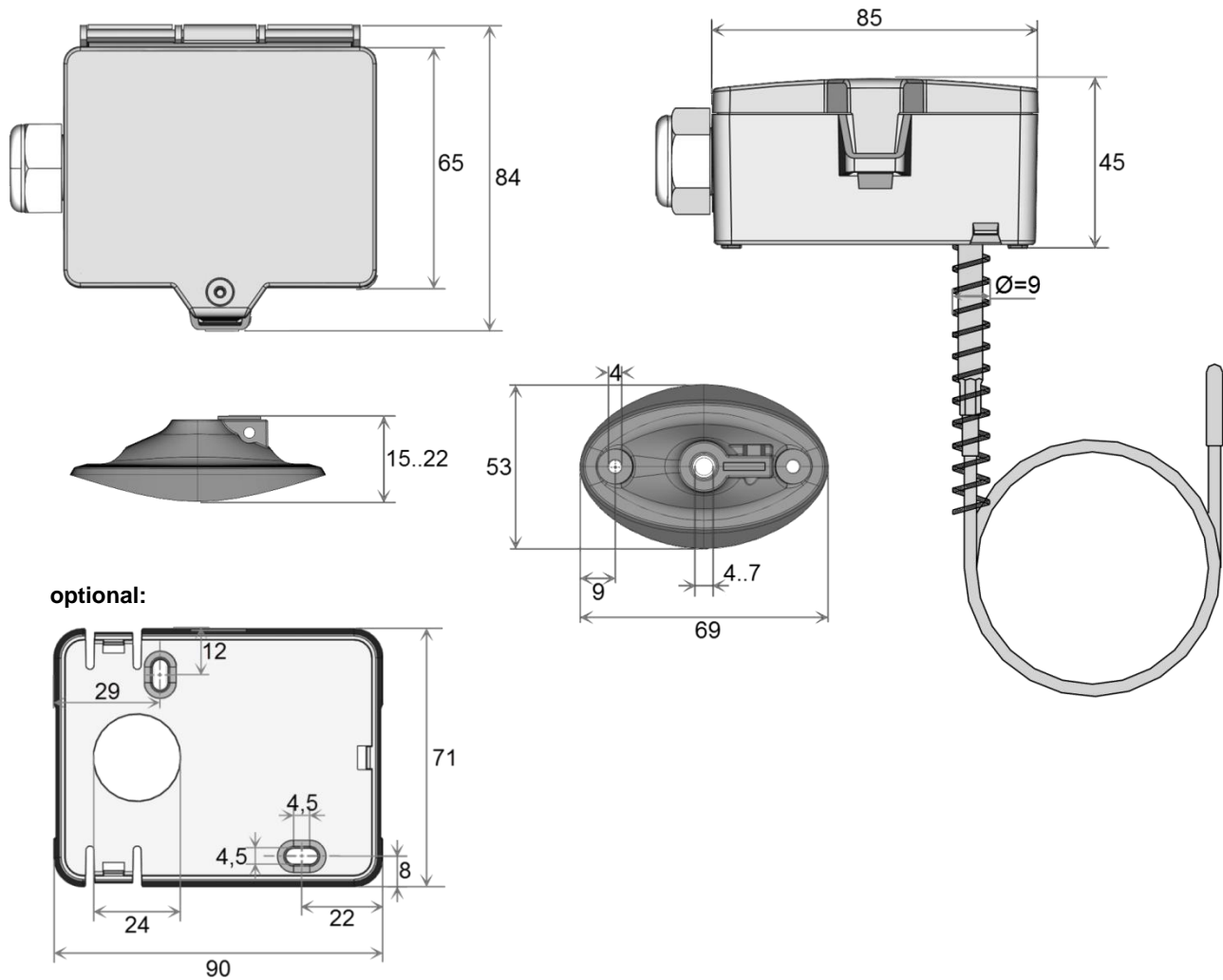

Accessories (included in delivery)

Mounting angle set
 Mounting flange MF6 flexible (incl. inserts for $\varnothing=4$ | 6 | 7 mm)
 Mounting kit universal
 • Cover screw + screw cover • 2 Rawplugs • 2 Screws (countersunk head) • 2 Screws (rounded head)

Item No. 458399
 Item No. 399098
 Item No. 698511

Accessories (optional)

Bluetooth dongle
 Cable entry M25 USE white, sealing insert 4x $\varnothing=7$ mm (4 pcs)
 Mounting base

Item No. 668262
 Item No. 641364
 Item No. 631228